

EC-171

Robotic Palletizer



The **EC-171** robot has the largest working envelope of all Fuji Robots while maintaining the smallest rotation radius. The **EC-171** is energy efficient using only 4 kva, still allowing the robot to work in tight space conditions and accomplishing a very high palletizing rate.

Operating Range

	Dimensions (mm)					
	A	B	C	D	E	F
EC-171	2143	663	1737	950	1600	2400

Details provide are for reference purposes only. All dimensions are in metric (millimeters)

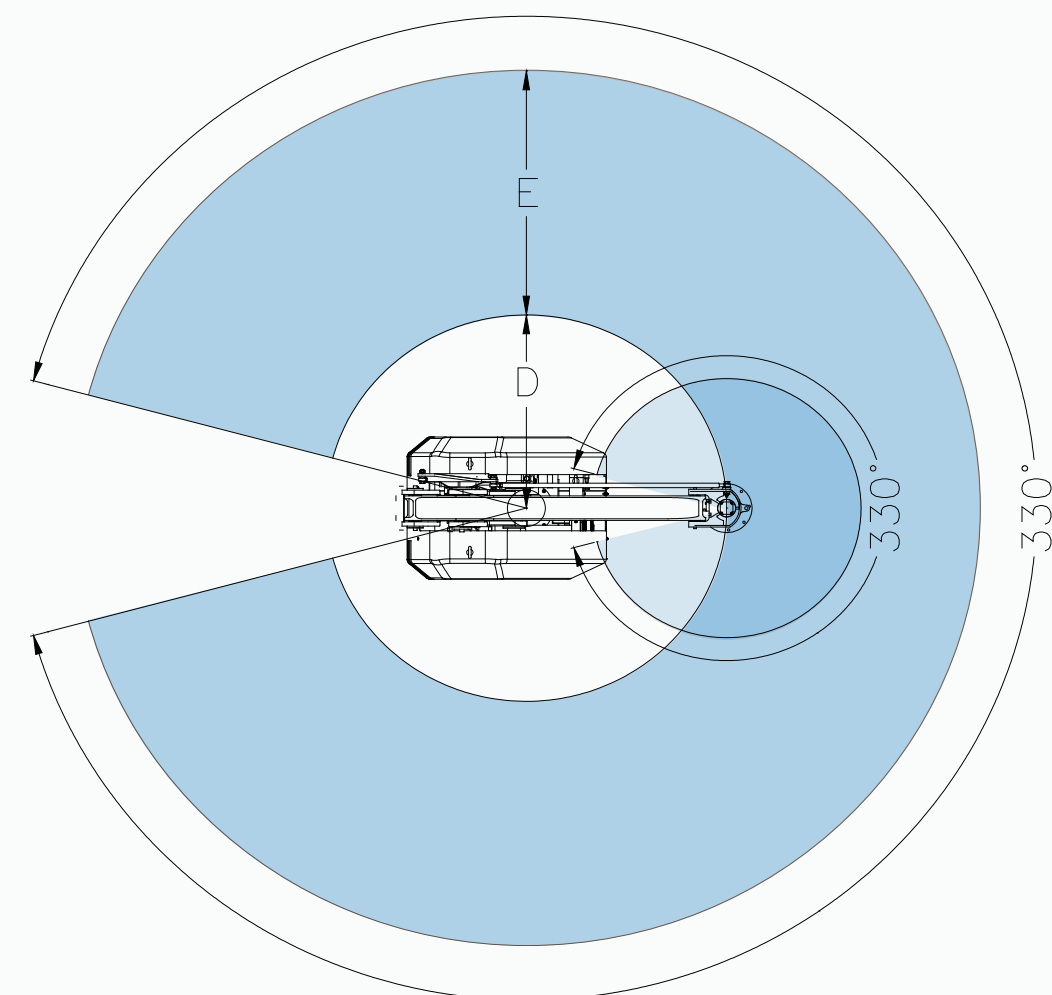
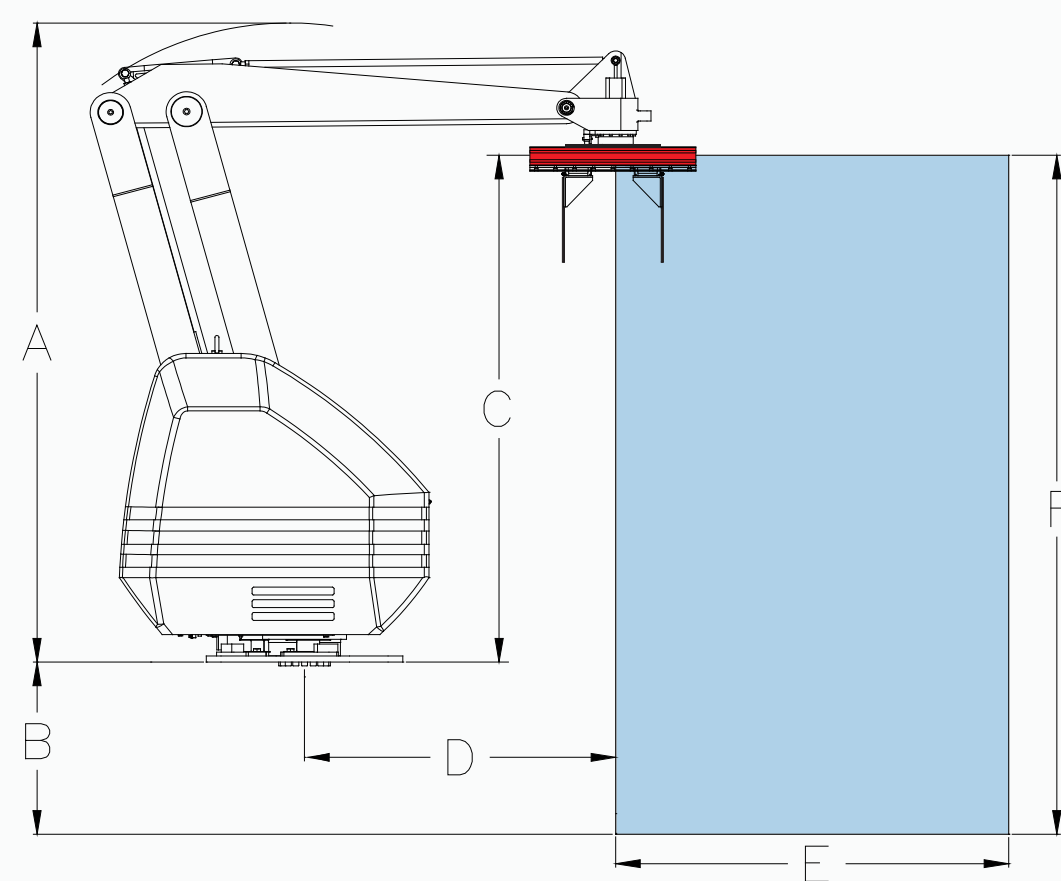

EC-171 Series Technical Specifications

Fuji ACE Model	EC-171	
Type of Motion	Multi-Articulated	
Action Mode	Cylindrical	
Load Capacity (Including End Effector)	80kg (176 lbs) or 130kg (287 lbs)	
Palletizing Capacity (cycles / hour)	1500 cycles/hour or 1000 cycles/hour	
Degree of freedom	4 axis	
Operating Area	Z axis (vertical)	2400 mm (94.75")
	R axis (longitudinal)	1600 mm (63")
	Theta axis (rotation)	330°
	Alpha axis (wrist)	330°
Repeatability	± 0.5mm	
Memory	400 programming locations available	
Teaching method	Teaching playback / Teaching Support	
Power Requirements	(208 / 220V, 3 phase, 50 / 60 Hz)	
Power Consumption (Without Peripheral Equipment Load)	4.0 kVA / 10.5 Amps	
Robot Weight (Without End Effector)	750 Kg (1654 lbs)	
Maximum Air Pressure	120 psi (0.827 MPa)	
Pneumatic Consumption (*Using Standard Fuji Case or Bag End Effector)	*5.7 SCFM @ 70 psi (.48 MPa)	

Note: Capacity rates can be significantly affected by layouts, product types, and can be confirmed after a detailed analysis of an application.